

edge banders, sizing edge banders

# stefani kd

single-sided automatic edge banders for the furniture industry



## STEFANI KD/FRT

QUOTE #: 000000    DATE: 00/00/2018

\*Photo may include optional equipment

### COMPANY NAME

CONTACT NAME:

ADDRESS:

## ABOUT SCM

PHONE #: (000) 000-0000

EMAIL:



SCM is an industry leader for the production of industrial woodworking machinery, as well as for machinery for wood processing advanced materials, with brands specializing in specific technologies, present across 5 continents for over 65 years.

**65** years of history

**3** main production sites in Italy

**20** foreign branches

**300,000** square meters of production space

**17,000** machines manufactured per year

**90%** export

**350** agents and dealers

**500** support technicians

**500** registered patents

# THE MOST IMPRESSIVE DISTRIBUTION NETWORK IN THE WORLD

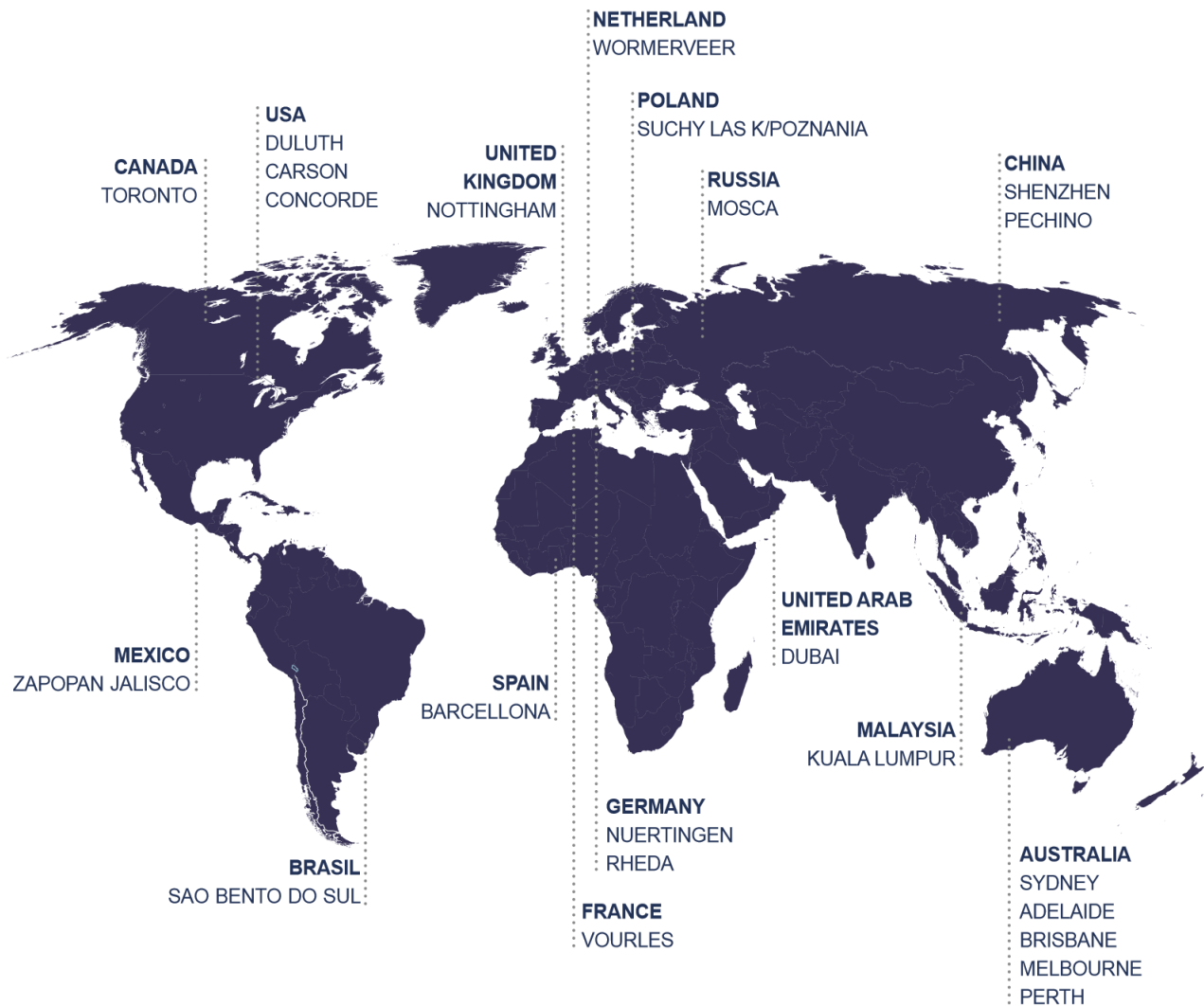

Dear **Customer**,

Thank you for your consideration in working with SCM. Attached is our proposal for the Stefani KDR. If SCM has inadvertently omitted any portion or feature requested by the customer upon agreement, please contact SCM sales personnel for further clarification about this price quotation.

We appreciate your business and we look forward to hearing from you soon.

Sincerely,

Tim Sermonet  
Product Manager  
Phone: 770-622-6608  
Mobile: 404-759-3504  
E-Mail: [tsermonet@scmgroup.com](mailto:tsermonet@scmgroup.com)

Equipment Finance:  
Kevin Mellon  
SCM North America Equipment Finance  
Mobile: 404-759-3575  
Fax: 770-813-8263  
E-mail: [kmellon@scmgroup.com](mailto:kmellon@scmgroup.com)

For all other general inquiries, please feel free to contact our offices below:

SCM North America  
2475 Satellite Blvd.  
Duluth, GA 30096-5808  
Phone: 770-813-8818  
Fax: 770-813-7880

SCM West Coast  
933 Sandhill Ave  
Carson, CA 90746  
Phone: 770-813-8818



# Stefani KD/HP – Single Sided Automatic Edgebander

Automatic single sided edgebander designed to be used for edgebanding straight vertical profiles with coiled material (veneer and PVC) and with strips (high-pressure laminate and solid wood) with a maximum thickness of 12mm.

## Machine Base

The machine base is a rigid, ribbed steel structure and is designed to provide maximum support for the working units. The ribs provide stability and, at the same time, provide openings in the base to facilitate removal of the chips/dust.

## Capacities And Speed

- Edgebanding thickness: .4mm - 12mm (.016-1/2")
- Guillotine capacity: 3mm
- Feed speed: 33-66 ft/min.
- Panel height: 3/8" min – 2 3/8" max
- Minimum panel length: 5 1/2"
- Minimum panel width: 2"
- Minimum distance between panels: 24"

**PC 21" Controller**

The Stefani KDR comes equipped with the Maestro Pro Edge controller, a 21" industrial multi touch screen. Comes standard with a Windows operating system. Capable of storing an unlimited number of programs. Monitors statistical data, as well perform diagnostic functions and program functions. 1920 x1080 resolution, intuitive interface. Monitors the number of panels processed, the amount of material applied, the number of hours run, the distance the feed track has turned, etc. Maintenance schedules are monitored for various stations throughout the machine. Swivels 270 degrees for easy access. Teamviewer for remote diagnostics is standard.



**Lighted Sound Enclosure With Acoustical Hoods**

Machine comes standard with a lighted sound enclosure making it easier for the operator to perform his daily functions. It is also equipped with an acoustical sound enclosure that covers the entire machine and reduces the noise level.

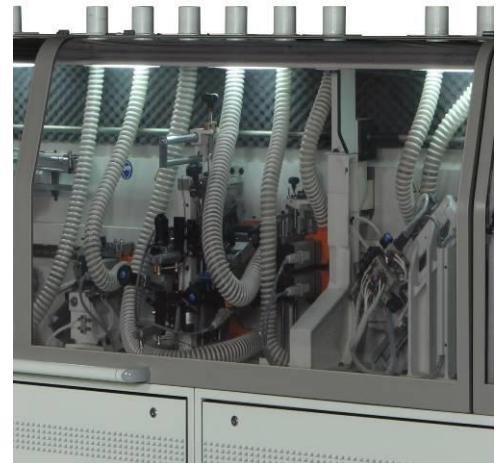

**Electronic Positioning Of The Top Pressure Beam**

All operating units raise and lower simultaneously when the pressure beam is adjusted. No adjustment is required for the glue roller when changing panel thickness. The pressure beam has two rows of staggered pressure rollers with steel bearings. The height of the pressure beam is electronically programmable through the controller.

**Anti-Adhesive**

The machine comes equipped with an anti-adhesive unit positioned prior to the pre milling unit. It prevents the buildup of glue on the top and bottom of the panel. The unit comes with two independent nozzles and a tank of anti-adhesive liquid.



**“QMS” Glue Station**

Automatically supplies the glue pot with the proper amount of glue on demand. The level of the glue in the glue pot is monitored by a sensor insuring the proper level. The pot is smaller, the glue is turned over faster as a result. The hopper holds in excess of 10 lbs. of glue and has sight glass to see what the level is. Teflon coated glue pot to facilitate glue changeover. Warm up time is approximately eight to ten minutes.

**An additional quick disconnect glue pot is included with the machine.**

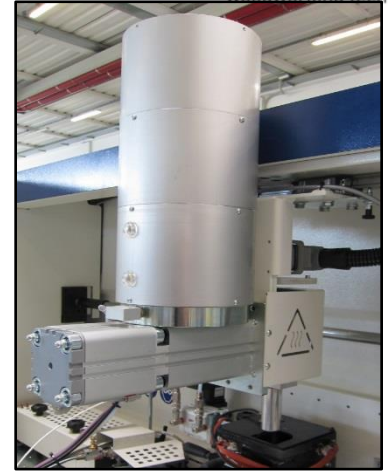

**SGP Glue Pot with CNC Control of the Glue**

Quick heat up time due to the small glue pot. Reverse rotation of the glue roller for the application of solid wood. Double Thermo Regulation for easy use of both EVA and PUR glue. Color change and glue pot cleaning are able to be completed in minutes, as opposed to hours. CNC control of the amount of glue being applied, specific to the program, is standard. Through the controller the operator can change the amount of glue being applied depending on the substrate of the panel. The purging process is CNC controlled as well when changing glue colors or going from EVA to PUR glue.



**Servo Driven Pressure Section**

There are a total of four pressure rollers for pressing the banding to the workpiece edge. The first roller is powered and applies pressure pneumatically. It is also Teflon coated to prevent the banding material from slipping. The three idle rollers have opposing one-degree tilt to provide extra pressure along the top and bottom edge. The unit comes standard with a servo driven motor for positioning. This eliminates the need for the operator to manually adjust the unit and helps reduce changeover time. The pressure section is also equipped with pneumatic jumping so the unit activates exactly on the leading/trailing edges. Standard is the edge detecting sensor that will shut down the feedtrack when there is no material present to be applied. Equipped with I-Glue, locks the glue roller in place at the end of the panel eliminating any excess glue.



**"AirFusion+ E" device for edge application ( 15 MT/MIN)**  
**Application of the co-extruded and pre-glued edge by means of the high temperature compressed air blower which allows to melt the specific functional layer of the edge and the following gluing to the panel.**

The device consists of:

two-stage air heating unit with double electronic temperature control. For an **optimal melting temperature control** of the functional edge layer, both temperatures can be set from the machine control.

air blower head, applied before the first edge pressure roller  
opening and closing adjustment of the head borings when varying the edge thickness, through knob and numeric indicator, carried out in a single operation together with the top edge guide

air blower on the edge activated only when the panel is present; in this way the **compressed air consumption is optimised**

**the spray-mist device for the edge cooling** (Riepe liquid LP289/99) positioned to the end of the edge pressure roller prevents the adhesion of the chips on the tools and improves the panel finishing

The device is **compatible with the standard gluing systems** for EVA and PU glue.

**With AirFusion+ E the following edges can be used:**

– co-extruded edge suitable for hot air melting and Laser in: PP, ABS and PMMA with 0,2 mm functional layer

– pre-glued edge with specific glue for working with hot air melting

***The devices does not allow the use of standard plastic and wooden edges.***

**Technical data with co-extruded edge**

– Working speed

\* edge height 35 mm – speed 10 m/min

\* edge height 30 mm – speed 12 m/min

\* edge height 23 mm – speed 15 m/min

*(working speed and edge height depend on the features of the used edge)*

– 1-3 mm edge thickness

– distance between panels according to the working speed and panel height

– 12 kW motor power

– 4 minutes heating time

– **max. compressed air consumption 1200 NI/min**

– **pressure of the compressed air 4 bar**

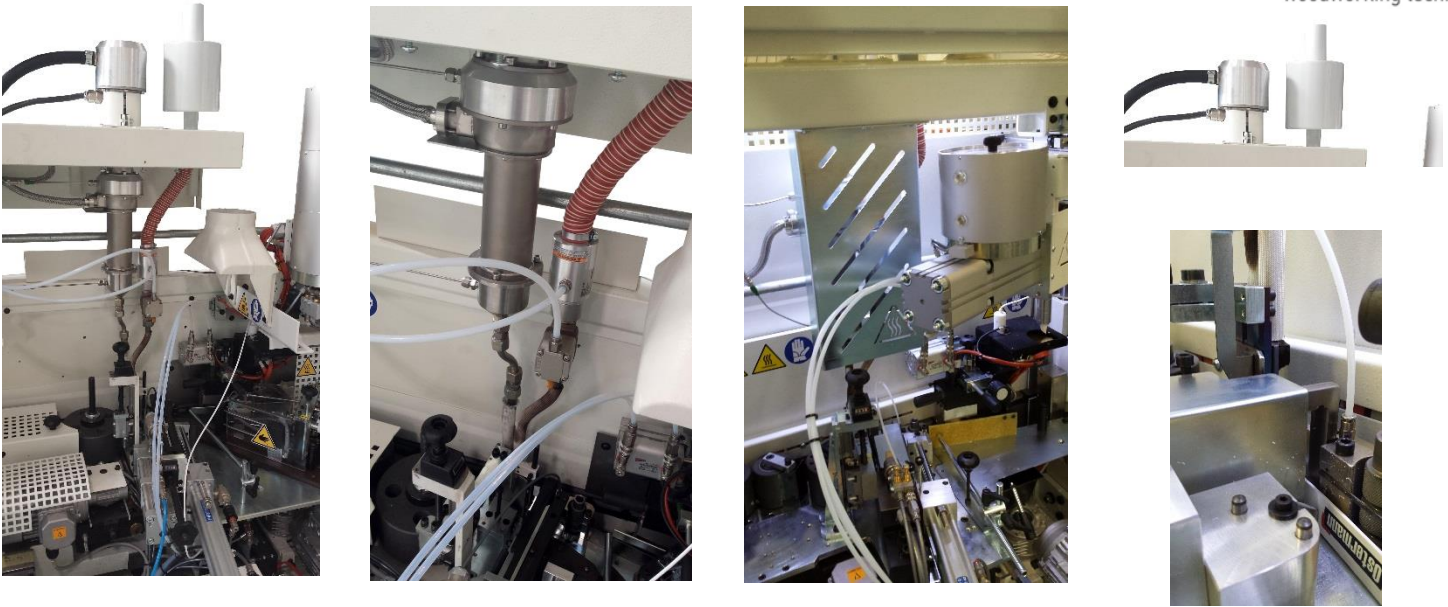

**Infeed Fence**

The infeed fence has a mechanical digital indicator to position the fence and determine the stock removal. It is also equipped with a pneumatic panel spacing device to prevent the operator from feeding the panels to close to one another.



**Air Cushion Table at Machine Entry**

Air cushion table located at machine infeed to help facilitate the loading of panels, especially panels of large dimensions. It includes the extension of the machine entry infeed fence. It is not possible to have the narrow feed option on the machine. Table dimensions are 1,600mm x 600mm.





**“RT-E” Pre-Milling Station:**

To rectify/clean panels already sized and squared before the edge is applied. The unit is composed of two high frequency motors with jumping action controlled through the PLC. The cutting heads are adjustable vertically. The unit is equipped with copying devices which guarantee that material removal is consistent on long or slightly out-of-square panels. 64mm tall diamond premill cutters with replaceable inserts come standard.



**“K-SEL 2” End Trimming Station**

This unit is composed of two independent .50 hp motors mounted on THK guides. End trim utilizes a draw cut system for reduced blade projection on thick panels. The unit comes standard with automatic tilting of the unit from the control panel with two preset positions. When operating in conjunction with the corner rounding station the unit is equipped with two position pneumatics to leave the material long, thus allowing the corner rounding unit to have a seamless finish.



**Flush Trimming Station:**

Two independent 1.0 hp motors operating at 12,000 rpm. The unit comes standard with two position pneumatics and is capable of cutting flush or leaving an overhang. Equipped with vertical copy shoes with digital indicators. Motors have quick release plugs to facilitate tooling changes. Pneumatic in/out positioning is standard.



This unit is composed of two independent .7 hp motors operating at 12,000 rpm. It comes standard with servo positioning to process TWO different radii and infinite thin edges all through the controller. Independently controlled positioning, ie radius on top and straight edge on the bottom. Four different controlled axes adjustments. The unit has top/bottom/side copy wheels. The motors have quick release plugs to facilitate tooling changes. The unit is equipped with a three roller nesting kit as standard, for processing panels with hinge holes and grooves.

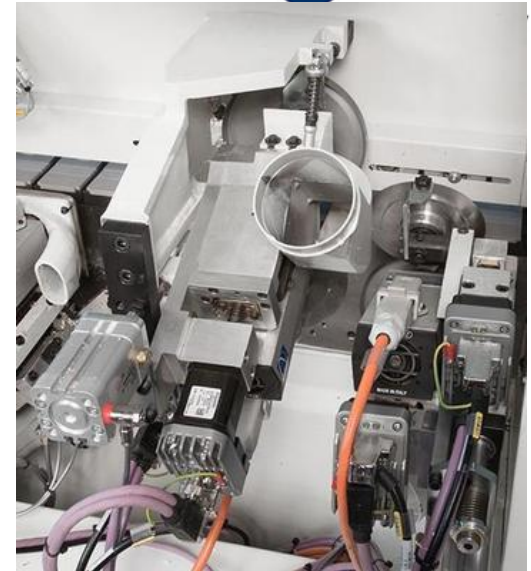
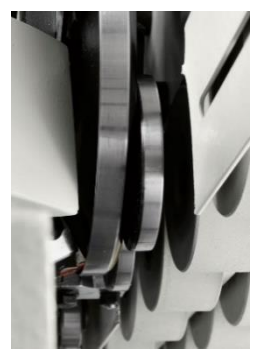
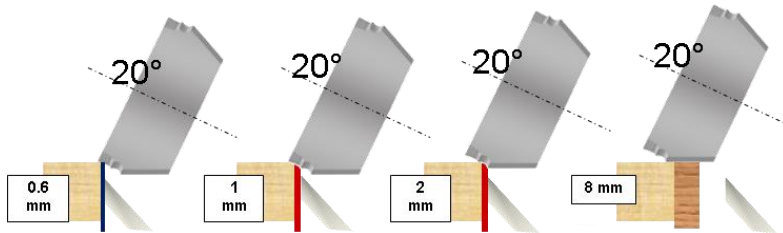

**“ROUND-K” Corner Rounding Unit:**

Two independent .80hp motors with servo positioning that slide on THK guides ensuring the highest quality finish. Unit is designed to work as an additional set of trimmers for rounding the top/bottom as well as the front/rear corners of work piece with 3mm PVC edges. The unit is equipped with front and lateral copying devices and pneumatic blowers to clean the panel. Dust shrouds surround the cutter and travel with the unit as it trims. The unit can go from thin tape to thick PVC, through the controller, with adjustments made through the controller as well.



**RAS Multi Edge 2R Profile Scraping Station**

The profile scraping station designed to remove knife marks from thick PVC. The unit is equipped with servo positioning to process TWO different radii. Includes tool with two different radii, four controlled axes adjustments and the ability to independently control the top from the bottom. It has a large diameter horizontal copy wheel and side copy wheel device. The unit comes standard with a three roller nesting kit for panels with hinge holes or grooves.

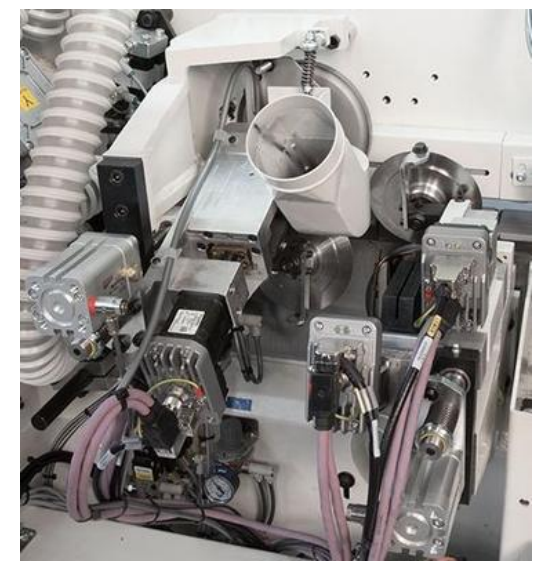
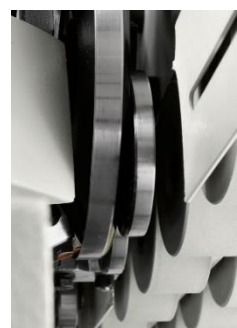

**“RCA/2C” Glue Scraping Station**

The glue scraping unit is for the finishing of thin PVC. It is equipped with two throwaway knives, vertical rotating copiers and blowers for tool cleaning. The unit is equipped with on/off pneumatic exclusion.



**“SPN” Buffing Unit And Hot Air Blower**

The buffing unit has two .25 hp motors. The unit cleans and polishes the panel edge. The unit oscillates to utilize the full width of the wheel and prevent rounding of the panel’s leading edge.

The hot air blower is designed to brighten the edges of thick PVC that can sometimes discolor during the machining process. The unit consists of a single hot air blower with adjustable heat range and a directional heat shield for coverage from the top to the bottom edge.



**Acoustical Safety Enclosure**

All working units are enclosed under an acoustical safety hood that is insulated to help reduce noise and prevent accidents. The hood has a safety microswitch which prevents the machine from operating when the hood is open. The machine has a decibel rating of 86db when operating.

**Dust Extraction**

Working units are individually ported on the top of the safety enclosure for maximum efficiency, per the drawing.

**Technical Specifications**

Glue Pot Unit:	
----------------	--

Heating Time	Approx. 8-10 min.
Glue Capacity	3.3 lbs.
Pre-milling Station:	
Horsepower	3.0 HP ea.
RPM	12,000 RPM
Max. Stock Removal	60mm <sup>2</sup>
Diameter/Bore/Height	100mm/30mm/64mm
End Cutting Trimming Station:	
Horsepower	.50 HP ea.
RPM	12,000 RPM
Tilting	0-15 degrees
Blade Diameter/Bore	100mm/32mm
Flush Edge Trimming Unit:	
Horsepower	1.0 HP ea.
RPM	12,000 RPM
Cutting Tools	70x20x16mm
Tiltable Edge Trimming Unit:	
Horsepower	1.0 HP ea.
RPM	12,000 RPM
Tilting	0-15 degrees
Cutting Tools	70x20x16mm
	1/2mm & 1/3mm
Corner Rounding Unit::	
Horsepower	.80 HP ea.
RPM	12,000 RPM
Cutting Tools	1/3mm Radius
Scraping Unit:	
Knife Radius	1/2mm & 1/3mm
Buffing Unit::	
Horsepower	.25 HP
RPM	3,000 RPM
Diameter/Bore	152mm/17mm
Feed Motor Horsepower	2.5 HP
Feed Speed	33-60 FPM
Frequency Converter	200 Hz
Pneumatic Operating Pressure	90 PSI
Machine weight:	8,254lbs.
Electrical:	117 amps @ 230v three phase
Dust:	3,500 cfm
Dimensions (LxWxH):	239" x 65" x 62" (add 45" for air flotation table)

## PRICE

**Machine Price:**

\$

**Delivery:**

**FOB Duluth, GA or Carson, CA**

**Installation:**

**Not Included**

**Terms of Payment:**

Terms of payment offered, or any terms agreed upon, are subject to credit approval. This offer is subject to SCM NORTH AMERICA General Terms and Conditions of Sale. Offer is subject to prior sale of the equipment. Quote expires in 30 days. Price quoted is for the machine as described above and is subject to change if the specifications for the machine are changed at the request of the buyer.

**Shipment:**

Shipment is subject to delay should changes be made to meet the requirements of purchaser from manufacturer's design specifications stated herein.

**Tooling:**

Tooling is not included. Upon request, we can supply a quotation on the most suitable tools required for use on this machine.

**Installation, Training, Service Rates and Conditions:**

Installation, when purchased, will be performed by an SCM factory trained service technician or Certified Dealer Technician. Installation is to be understood as the assembly of the machine to the 'ready-to-run' state; it does not include floor, masonry work, the running of electrical, pneumatic or dust extraction services to the site. Training will be conducted on site by the service technician after installation has been completed.

SCM is committed to maximizing your production time. Your machine may be preselected to contain automatic maintenance reminders. You can contact SCM North America Service Department at 866-216-2166 if and when you receive a maintenance message.

**Product Registration:**

Upon arrival of your machine, locate the red label with instructions on how to register your machine.



**ATTENTION: MACHINE REGISTRATION REQUIRED**

REGISTER YOUR MACHINE IN JUST A FEW SIMPLE STEPS

**Mobile**

Scan the QR code below  
Fill out required fields  
Receive email confirmation

**Web instructions**

Visit [scmgroupna.com](http://scmgroupna.com)  
Go to the Service tab and click  
Product/Event Registration tab  
Fill out required fields  
Receive email confirmation

**Register today and receive:**

- Automatic maintenance reminders
- Online on-exchange web-to-ftp tool
- Online and more efficient service and support
- Exclusive discounts and special offers

SCM North America | 866-216-2166 | [www.scmgroupna.com](http://www.scmgroupna.com) | [na@scmgroupna.com](mailto:na@scmgroupna.com) | 866-216-2166 

**Warranty:**

SCM warrants that the machinery will be free of defects in workmanship and materials for a period of one (1) year beginning on the date the machinery is accepted by the customer. This warranty includes belts, bearings, and common electrical parts, which carry a six-month warranty. This warranty does not include parts consumed during normal operation (wearable items) or maintenance required in the ordinary course of operation.



**EA ERC Series of Return Conveyors**

SCM is pleased to provide a standard ERC Series Conveyor to be paired with a **machine model**. The edgebander, coupled with an ERC, streamlines workflow and creates a very productive work center for banding parts with a single operator.

The result is labor savings, machine efficiency, less handling damage and less rejects. The machine has independent adjustable speed control on the receiving table, transfer belts, and return conveyor, allowing the operator to balance all three for a customized perfectly balanced system.

**Workpiece Requirements:**

Length:*	300 - 2,500 mm	12" - 98"
Width:	55 - 1,625 mm	2 1/4" - 64"
Thickness:	10 - 60 mm	3/8" - 2 3/8"
Weight:	part length ≤ 700 mm:	30 kg 66 lbs.
	part length > 700 mm:	45 kg 100 lbs.

\*Length is defined as the side of the panel where the edgebanding is being applied

as the side of the

**Four Sided Edgebanding Specifications with Return Conveyor:**

Panel Dimensions:	<b>Min</b>	300 x 300 mm	12" x 12"
	<b>Max</b>	1,320 x 1,320 mm	52" x 52"

**Panel Spacing Specifications:**

Machine Feed Speed		Min. Distance between Panels	
12 m/min	40 ft/min	600 mm	24"
18 m/min	60 ft/min	700 mm	28"

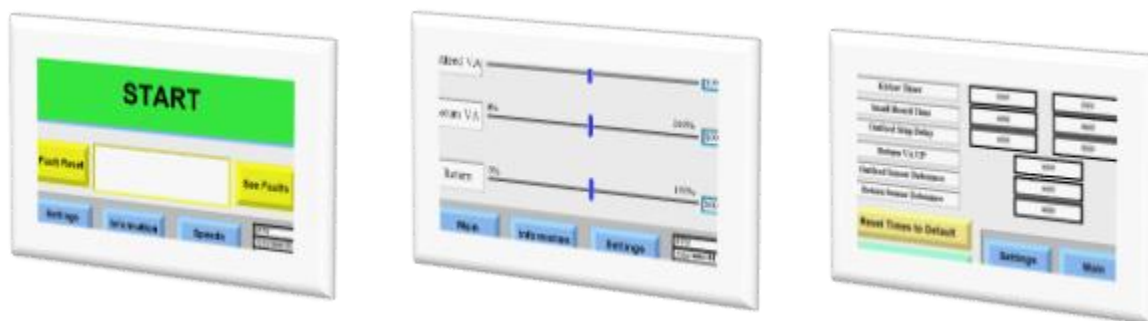

**7" Touchscreen Controller**

Every ERC conveyor comes standard with a 7" color touchscreen controller. The operator is able to customize the feed speeds per the size of the panels being ran. The operator has individual speed control of the receiving table speed, the transfer table speed and the return table speed. The controller is located at the outfeed end of the machine on the top of the electrical panel, with manual controls for the emergency stop and on/off switches located at the infeed end of the conveyor.



The conveyor comes standard with steel rollers with a non-marring urethane coating, as well as steel ball bearings. This is a more expensive option that replaces the use of pvc rollers that can warp over time.



### Panel Rotating Device

The unit comes standard with the Panel Rotating device. This allows the operator to process the short sides of long and narrow panels. The panels get rotated a full 90 degrees as part of the transfer process between the receiving/transfer table and the return rollers. This prevents the panel from hanging over the rollers and possibly getting damaged.



### Panel Kicker Device

The unit comes standard with the Panel Kicker device. This helps with the feeding and flow of smaller parts that are less than 6" wide that potentially can get hung up on the receiving table. allows the operator to process the short sides of long and narrow panels. The panels get rotated a full 90 degrees as part of the transfer process between the receiving/transfer table and the return rollers. This prevents the panel from hanging over the rollers and possibly getting damaged.

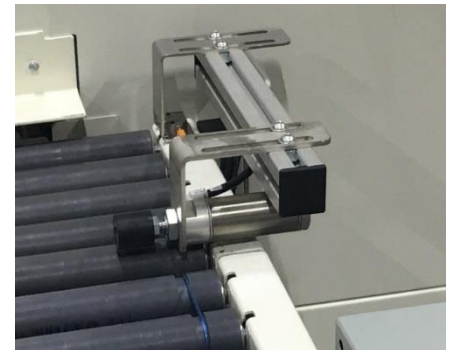



The ERC Series 900/1,600/**machine length** is specifically designed to work with the **machine model** edgebander outlined in this proposal. Other return conveyors, in differing lengths and widths, specific to your application are available upon request.

The Return Conveyor will be configured as follows:

- Motorized **Machine Mate** transfer roller section for connection to edgebander
- 900mm wide x 1,600mm long receiving conveyor with 48mm Ø Steel rollers on 65mm centers.
  - Receiving table consists of two vertically actuated roller sections
  - Belt transfer unit features 9 transfer belts
- 900mm wide x LENGTH return conveyor with 48mm Ø Steel rollers on 65mm centers
  - Last rollers can be made idle by removing the drive belts
- Transfer by-pass switch
- Separate speed control for Receiving Table, Belt Transfer and Return
- Conveyor sequence controlled by mini-PLC
- Manual Controls to include:
  - Start. Stop
  - 3 x Speed Pot
  - Transfer mode
  - By pass
- SCM White Color RAL9002
- Voltage: 480 / 3 / 60, 5 amps (240 / 3 / 60, 10 amps)
- Compressed air requirement: 10 cfm @ 90 psi

Available in Different Lengths and Widths

Stock Units with both 3' and 4' Wide Rollers

Receiving Table Available in 62" and 96" Lengths

EDGE AUTOMATION:  
 ERC SERIES STANDARD CONVEYOR  
 900|1600|CONVEYOR LENGTH

CONVEYOR ROLLER WIDTH: 900MM  
 RECEIVING TABLE LENGTH: 1600  
 POWER REQUIREMENT: 480V 3 60HZ

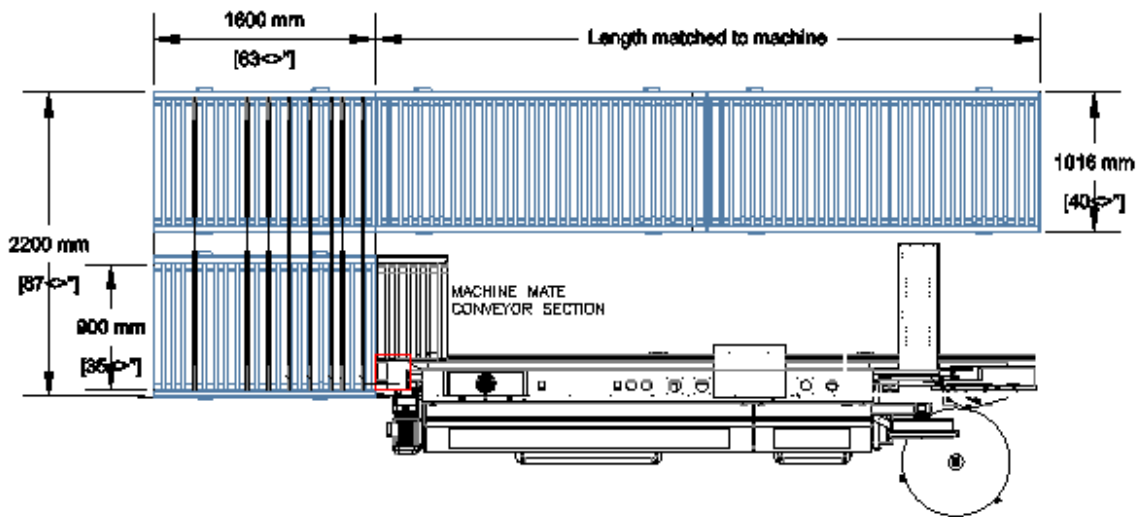

## PRICE

Machine Price:

\$ 00,000.00

Delivery:

FOB London, Ontario

Installation:

Not Included

## Product Registration:

Upon arrival of your machine, locate the red label with instructions on how to register your machine.

**ATTENTION: MACHINE REGISTRATION REQUIRED**

REGISTER YOUR MACHINE IN JUST A FEW SIMPLE STEPS

**Mobile**

Scan the QR code below

Fill out required fields

Receive email confirmation



**Web Instructions**

Visit [scmgroupna.com](http://scmgroupna.com)

Go to the Service tab and click Product/Event Registration tab

- Fill out required fields
- Receive email confirmation

Register today and receive:

- Accurate material handling data
- Register at time of purchase
- Offer an extended warranty option
- Quicker and more efficient service and support
- Get access to discounts and special offers

SCM North America | scm@scmgroupna.com | 2200 West Beaver Creek Rd. | Suite 200 | Richmond Hill, ON L4B 1R2 | 905.219.2199



## Warranty:

SCM warrants that the machinery will be free of defects in workmanship and materials for a period of one (1) year beginning on the date the machinery is accepted by the customer. This warranty includes belts, bearings, and common electrical parts, which carry a six-month warranty. This warranty does not include parts consumed during normal operation (wearable items) or maintenance required in the ordinary course of operation.

# SERVICE & SPARE PARTS

A CONTINUOUS COMMITMENT TO PROTECT YOUR INVESTMENT

Visit our website at [www.scmgroupspareparts.com](http://www.scmgroupspareparts.com)

## SERVICE

Email us at [service@scmgroup.com](mailto:service@scmgroup.com)

SCM provides a service that goes beyond the purchase, to guarantee the long term performance of your technological production system and peace of mind for your business.

### A COMPLETE RANGE OF AFTER-SALES SERVICES

- Installation and start-up of machines, cells, lines and systems
- Tailored training programs
- Telephone support to reduce times and costs when machines are experiencing down time
- Preventive maintenance programs to guarantee long term performance
- Complete renovation of machines and plants to renew the added value of your investments
- Custom upgrading to update machines and plants to meet new production requirements

## SPARE PARTS

Email us at [spareparts@scmgroup.com](mailto:spareparts@scmgroup.com)

**Parts Pronto – your one-stop shop for all spare parts and service needs [www.scmgroupspareparts.com](http://www.scmgroupspareparts.com)**

SCM has 140 spare parts professionals worldwide to meet any request with real-time shipments.



Our spare parts inventory, with a value of 15 million dollars, covers every single machine.



Spare parts guaranteed: we guarantee also hard to find parts, with 3.5 million euros invested in “critical” spare parts.



Immediate availability: over 90% of orders received are carried out the same day thanks to the huge inventory available.



6 branches around the world: The spare parts service can count on worldwide support (Rimini, Singapore, Shenzhen, Moscow, Atlanta, Sao Bento do Sul).



500 shipments a day





# Equipment Finance Application

Company Name: \_\_\_\_\_ Email \_\_\_\_\_

Address:

Address: \_\_\_\_\_ City: \_\_\_\_\_ State: \_\_\_\_\_ Zip: \_\_\_\_\_

Phone: \_\_\_\_\_ Fax: \_\_\_\_\_ Years in Business: \_\_\_\_\_

Address of Equipment location: \_\_\_\_\_

Company Website: \_\_\_\_\_ Tax Exempt  Yes  No Fed ID #: \_\_\_\_\_

Check One:  Corp.  LLC  Partnership  Sole Prop. State of Incorp: \_\_\_\_\_

**Bank: Include copy of first page of Company's most recent 3 months bank statements**

Vendor Name: \_\_\_\_\_ Contact: \_\_\_\_\_ Equipment Cost: \_\_\_\_\_

Equipment Description (attach sales order if available): \_\_\_\_\_

**Please complete the following information, and signature, of each officer:**

1) Owner's Name: \_\_\_\_\_ Title: \_\_\_\_\_

Social Security Number: \_\_\_\_\_ % Owner: \_\_\_\_\_

Address: \_\_\_\_\_ City: \_\_\_\_\_ State: \_\_\_\_\_ Zip: \_\_\_\_\_

2) Owner's Name: \_\_\_\_\_ Title: \_\_\_\_\_

Social Security Number: \_\_\_\_\_ % Owner: \_\_\_\_\_

Address: \_\_\_\_\_ City: \_\_\_\_\_ State: \_\_\_\_\_ Zip: \_\_\_\_\_

3) Owner's Name: \_\_\_\_\_ Title: \_\_\_\_\_

Social Security Number: \_\_\_\_\_ % Owner: \_\_\_\_\_

Address: \_\_\_\_\_ City: \_\_\_\_\_ State: \_\_\_\_\_ Zip: \_\_\_\_\_

I hereby certify that the information contained in the lease application is true and accurate and I hereby authorize our banks, trade references and financial institutions the right to release credit information. In states where permissible, I hereby authorize the filing and recording of UCC financing statements showing the Secured Party's interest in the equipment and grant the Secured Party's right to execute lessee's/debtors name thereto. A photocopy of this authorization shall be as valid as the original.

Signature: \_\_\_\_\_ Title: \_\_\_\_\_ Date: \_\_\_\_\_

**Please fill out the information and submit to:**

SCM Equipment Finance  
2475 Satellite Blvd  
Duluth, GA 30096

Phone: 800.292.1837  
Fax: 770.813.8263  
[financing@scmgroup.com](mailto:financing@scmgroup.com)

Blair Chandler  
[blair.chandler@scmgroup.com](mailto:blair.chandler@scmgroup.com)  
770.238.8500

Max Mellon  
[mmellon@scmgroup.com](mailto:mmellon@scmgroup.com)  
770.655.6876