







Ligne automatisée d'application de teinture - Stain automated application line

<p>T1 (2 Convoyeurs)</p>  <p>Convoyeur à rouleaux motorisés Motorized conveyor BARBERAN MMV-3500/1800</p>	<p>T2</p>  <p>Brosse avec aspiration Brush with suction BARBERAN LP-1800</p>	<p>T3</p>   <p>Inox KREMLIN REXSON & SAMES Pistolet A35 HTI -</p> <p>Robot d'application en pulvérisation Automatic spray booth BARBERAN RR-B8</p> <p>Specifications : 2 circuits d'application indépendants 8 fusils pour l'application de la teinture</p> <p>Specifications : 2 independant circuits for applying 8 guns for spraying</p>	<p>T4</p>  <p>Table de transport avec aspiration Transport table with suction BARBERAN MTB-3500/18</p>	<p>T5</p>  <p>Tunnel de séchage de teinture (convection) Drying tunnel (convection) BARBERAN TSP+E+MT</p>	<p>T6</p>  <p>Convoyeur à rouleau motorisé Motorized conveyor BARBERAN MMV-3500/1800</p>
--	--	--	--	---	--

Spécifications

- Année (Year) : 2009
- Hr d'utilisation (Hr of use) : 8000 hr
- Vitesse de la ligne (Line Speed) : 1 - 12 mètres/min (3 - 39'/min)
- RPM (Carousel) : 1 - 25 RPM (nb de tours/minute)
- Nb lignes d'application (# of Paint Lines) : 2
- Nb Fusils (# of Paint Guns) : 8 par ligne + 1 back-up (Total : 17 Fusils/Guns)
- Récupération de produits (Products recovery) : Oui (Yes)
- (Products recovery) : Excédent de produits récupéré/réutilisé
- Produits (Products) : À base d'eau et de solvant (Water base/Solvent)
- Temps de mise en course (Set-up time) : 1^e ligne : 2 min / 2^e ligne : 0 min
- Largeur minimale (Min. Width) : 2"
- Largeur maximale (Max. Width) : 60"
- Longueur minimale (Min. Length) : 6"
- Longueur maximale (Max. Length) : illimité (unlimited)
- Variation en hauteur des fusils (Height variation of guns) : 80 - 215mm (3 1/8" - 8 3/8")
- Temps de cycle (Cycle Time) : 6,5 minutes (4 mètres/min, 13'/min)
- Température du four (Oven temp) : 20° - 200° C
- Voltage : 400V

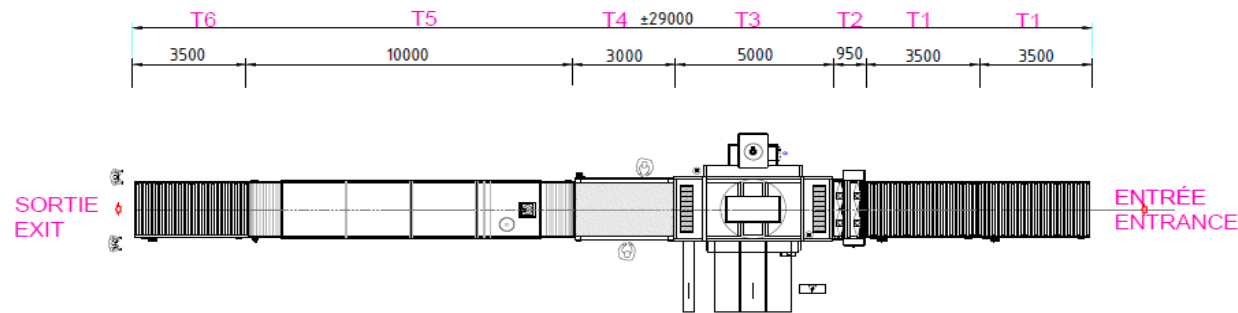

- | | |
|--|--|
| <p>T1 = Convoyeur à rouleaux motorisés</p> <p>T2 = Brosse avec aspiration</p> <p>T3 = Robot d'application</p> <p>T4 = Table de transport avec aspiration</p> <p>T5 = Tunnel de séchage de teinture (convection)</p> <p>T6 = Convoyeur à rouleaux motorisés</p> | <p>T1 = Motorized conveyor</p> <p>T2 = Brush with suction</p> <p>T3 = Automatic spray booth</p> <p>T4 = Transport table with suction</p> <p>T5 = Stain drying tunnel (convection)</p> <p>T6 = Motorized conveyor</p> |
|--|--|

