

jointer planer combination machine

minimax fs 41 es

jointer planer combination machine



*Photo may include optional equipment

Minimax FS 41ES T

[Minimax FS 41ES Showcase Video](#)

Jointer Planer Combination Machine

The Minimax FS 41ES T is a professional grade, heavy duty, long bed jointer/planer combination machine designed to meet the needs of the most demanding environments. It features heavy cast iron tables, an 8 horsepower single-phase motor and a tilting fence.

TERSA CUTTERBLOCK

The planer unit stands on cast iron supports and the standard version has a 95mm diameter "Tersa" cutter block with 4 quick tightening knives and automatic adjustment. For an impeccable finish, the pressure of the thickener feed rollers can be adjusted according to the type of wood machined. The infeed roller has a helicoidal profile to guarantee firm and constant work piece feed, while the outfeed roller, in sandblasted steel, maintains the perfect post-processing finishing.



AMERICAN CUTTERHEAD GUARD

Shown here, the standard guard offered on the Minimax jointer/planer combination machine is a spring type guard which always covers the unused portion of the knife. Other style guards require the guard to be manually moved into place when the fence is readjusted. When processing thick wood, this does not cover the blade as completely.



STABILITY OVER TIME

For a maximum long lasting stability the cast iron thickening table lifts on 4 spindles with dust protected trapezoidal threads.



HIGH RIGIDITY

The Minimax FS 41ES T uses a dedicated planing fence extremely rigid and smooth, thanks to a support with central round bar.



TABLE LIFTING

Comfortable and precise planing. The ES series adopts ergonomic solutions like the 2200mm jointer tables, in ribbed cast iron, that allows for the simultaneous opening towards the inside of the machine with a 90° angle. For maximum long lasting stability the cast iron thickening tables lift on 4 spindles with dust protected trapezoidal threads.



STANDARD EQUIPMENT

- 4.8hp motor 1ph (1x230v)
- Parallelogram jointer tables
- 4 post planer table
- Digital-mechanical readout on planer height
- LED readouts & powered movements available on request (3ph machine)
- 4-knife "Tersa" jointer/planer cutterhead & 4 post planer bed support
- American-style jointer guard
- Wheels for machine movement

OPTIONAL EQUIPMENT

- Cast-iron horizontal mortiser
- Euro-style jointer guard

TECHNICAL SPECIFICATIONS

JOINTER SPECS	
Working width	16"
Overall table length	87"
Cutterhead speed / diameter	5000 rpm / 4"
Maximum depth of cut	0.1875"
Fence tilt	0° - 45°
PLANER SPECS	
Table Size	16.125" x 30.5"
Maximum working thickness	9.4375"
Minimum working thickness	0.125"
Maximum stock removal	1/8"
Feed speeds	23 & 46 fpm
Single-Phase motor	4.8 Hp
Dust Extraction	1000 cfm
Weight	1285 lbs
	FS 41ES T 1PH Surfacing/Thicknessing Jointer Planer
R0.22.00	Minimax FS 41ES Usa/Canada version
93.07.58	230 volt
93.12.15	Frequency 60Hz
58.02.23	"Tersa" cutterblock Ø 95mm with 4 knives with rapid locking system
58.02.50	Wheels for machine movement
58.03.37	Single-phase motor 4.8Hp (3.6kW) 60Hz
58.02.41	Additional overturning fence for processing for thin workpieces
08.06.25	Triple Wall

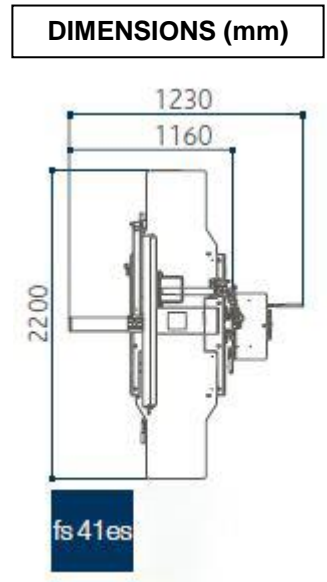

Specifications are subject to change