

★ Anschluss für betriebliche Absauganlage (rechts oder links)
 Raccordement pur une installation d'aspiration annexe (droite ou gauche)
 Connection point for user's own extraction system (right or left)
 Raccordo per impianto aspiratore aziendale (destra o sinistra)

● OPTION: Plattenabsenkvorrichtung
 OPTION: Dispositif d'abaissement des panneaux
 OPTION: Panel lowering device
 OPZIONE: Dispositivo di abbassamento pannelli

Freistehende Montage
 Montage en appui libre
 Free standing assembly
 Montaggio libero

Wandmontage
 Montage contre mur
 Wall assembly
 Montaggio contro parete

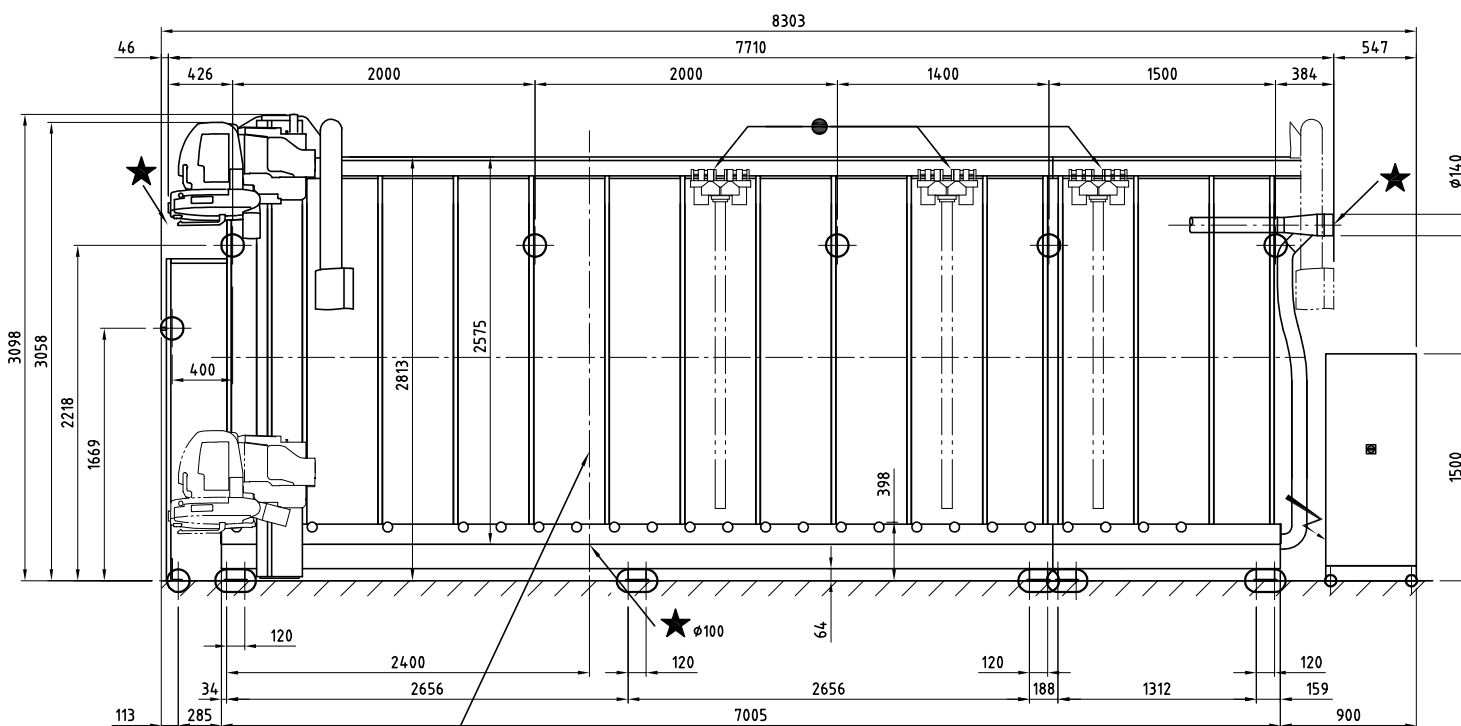

Vertikalschnitt-Nullpunkt
 Point zéro de la coupe verticale
 Zero point for vertical cutting
 Punto zero per il taglio verticale

Horizontaltrennung
 Bâti séparé en direction horizontale
 Frame horizontally separated
 Telaio sezionato orizzontale

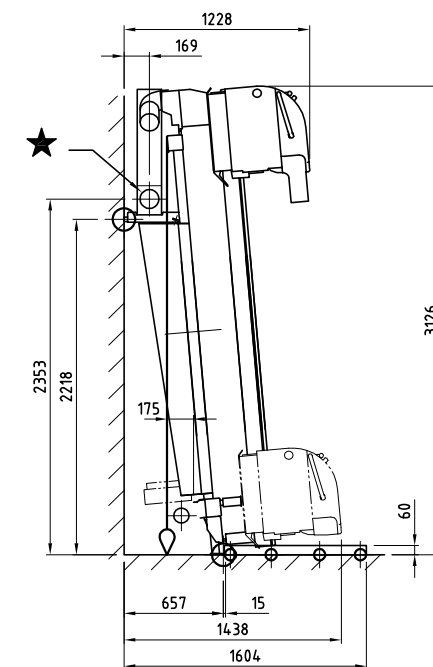
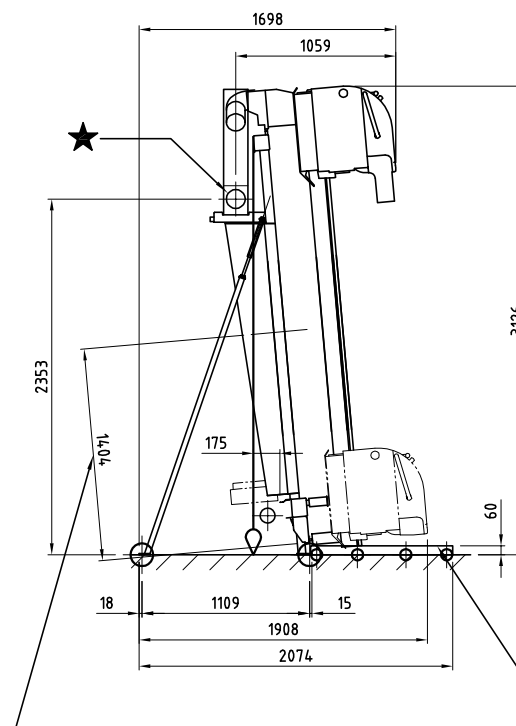

Sicherheits Lichtvorhang (Montagezeichnung 030.382)
 Barrage de sécurité (Dessin d'assemblage 030.382)
 Safety light curtain (Assembly drawing 030.382)
 barriera di sicurezza (Disegno di montaggio 030.382)

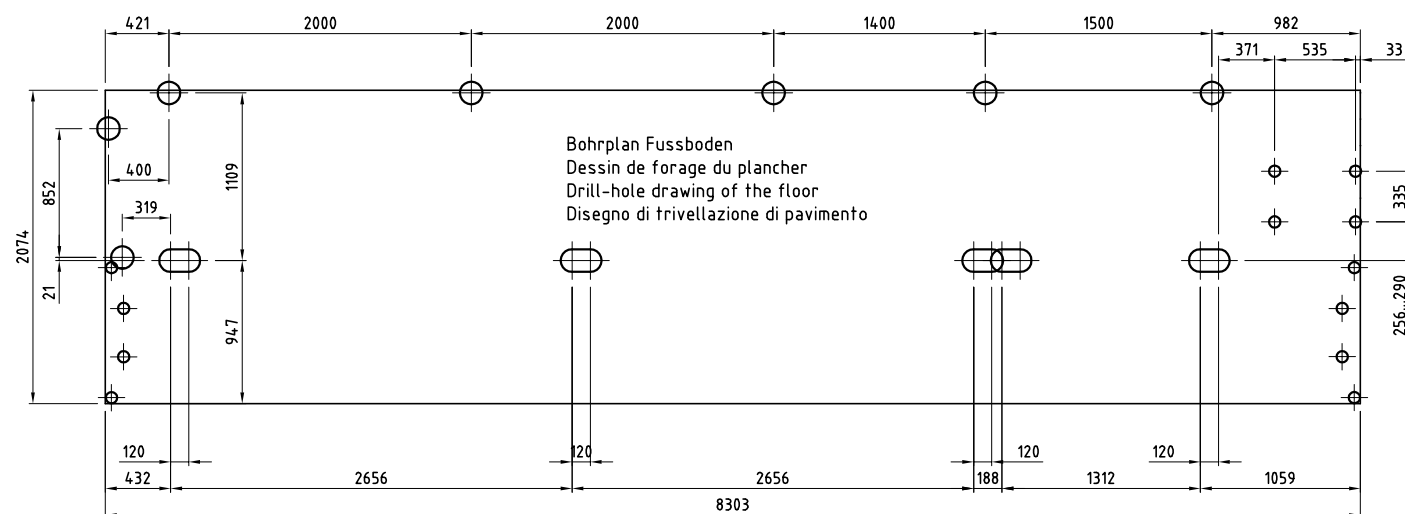

Bohrplan Fussboden
 Dessin de forage du plancher
 Drill-hole drawing of the floor
 Disegno di trivellazione di pavimento

Netzanschluss Branchement électrique Mains connection Allacciamento alla rete		Luftanschluss Raccordement d'air Air connection Attacco aria	
 Min. 16AT (400V) Max. 25AT (400V)	L1, L2, L3, N max. 6mm ² (AWG 10)	PE 10mm ² (AWG 6)	
Anschlusswert Puissance connectée Wattage Potenza allacciata		7.5 kW Pmin 6 bar ü Pmax 10 bar ü min. 2.5m ³ /h	

Technische Aenderungen vorbehalten
 Sous réserve de modification techniques
 Technical alternations reserved
 Modificazioni tecnici riservati

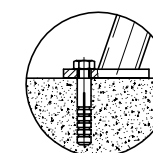

Befestigungsdübel
 Tampon de fixation
 Fastening dowel
 Caviflita di fissaggio

Montagezeichnung
 Dessin d'assemblage
 Assembly drawing
 Disegno di montaggio

Modell
 Modèle
 Model
 Modello
STRIEBIG 4D

Typ
 Type
 Type
 Tipo
7224

Schnitttiefe
 Profondeur de coupe
 Cutting depth
 Profondità di taglio
70/80

STRIEBIG

130.783 mv, jv 01.06.16