

NC-442PMC-1616M SPECIFICATIONS

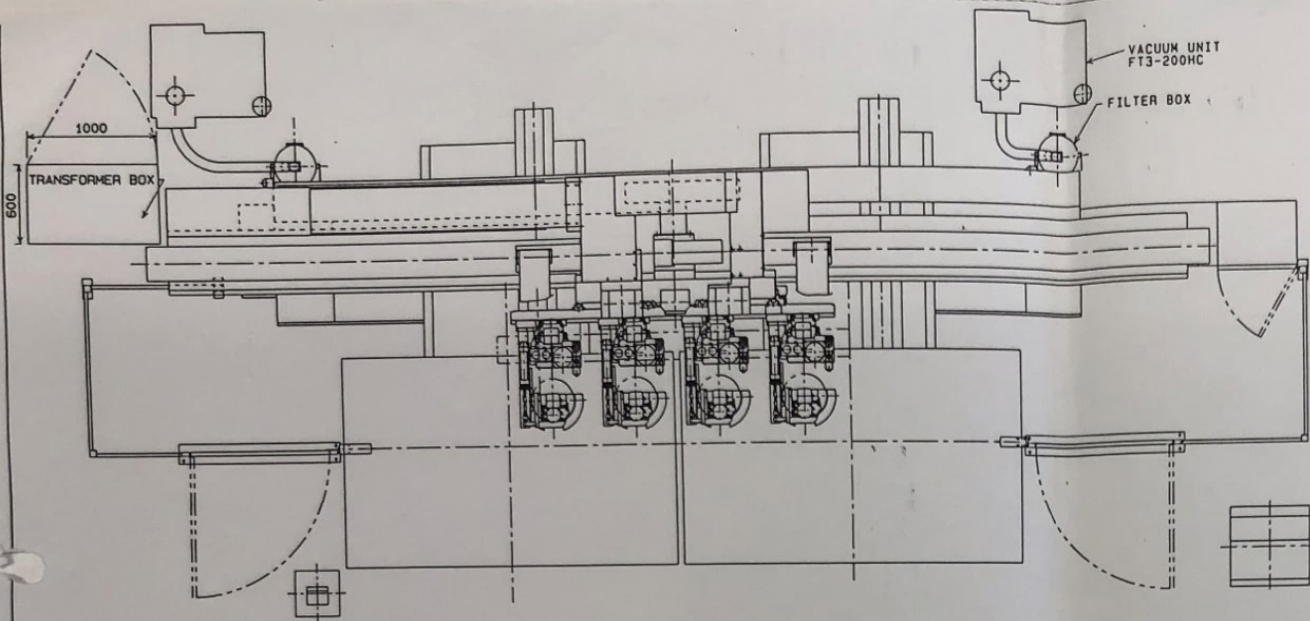

1. Spindles		3. Table		
ATC Router Head	Power	7.5kW 2P	Table size	2600X1600 <sub>±</sub> X2pcs.
No. 1, No. 2	Speed	max 18000rpm	Blower unit	7.5kW X 2pcs.
No. 3, No. 4	Spindle nose	NT35	4. Stroke and Rapid Speed	
2. Tool magazines for ATC		X axis	6000 mm - 24 m/min	
Tool capacity	8 tools each	Y, Y axis	1600 mm - 24 m/min	
Tool diameter	max 120mm	Z axis	250 mm - 6 m/min	
Tool length	max 150mm	5. NC Device		
Tool weight	max 4kgf	SYSTEM 1801 (FANUC)		
Tool shank	MAS BT35	6. Airpress Req.		
		5kg/cm <sup>2</sup> G (500N1/min)		
		7. Machine Size		
		9440* X 3450* X 3217*		
		8. Machine Weight		
		17000kgf		

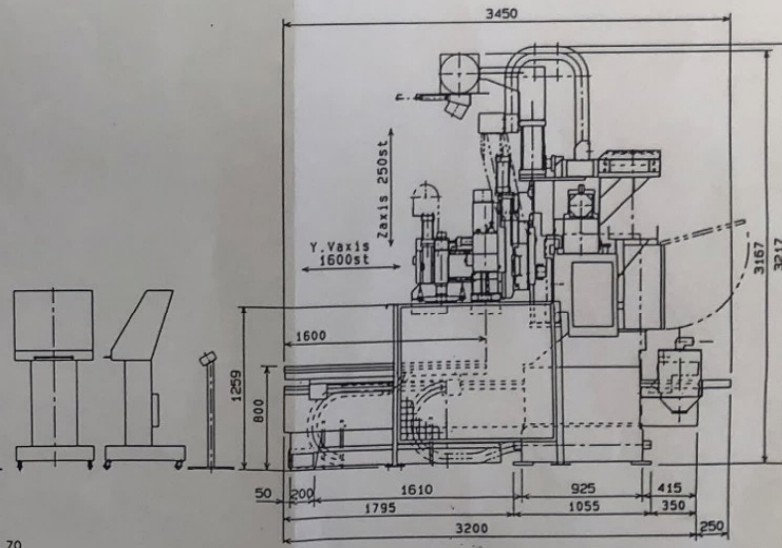
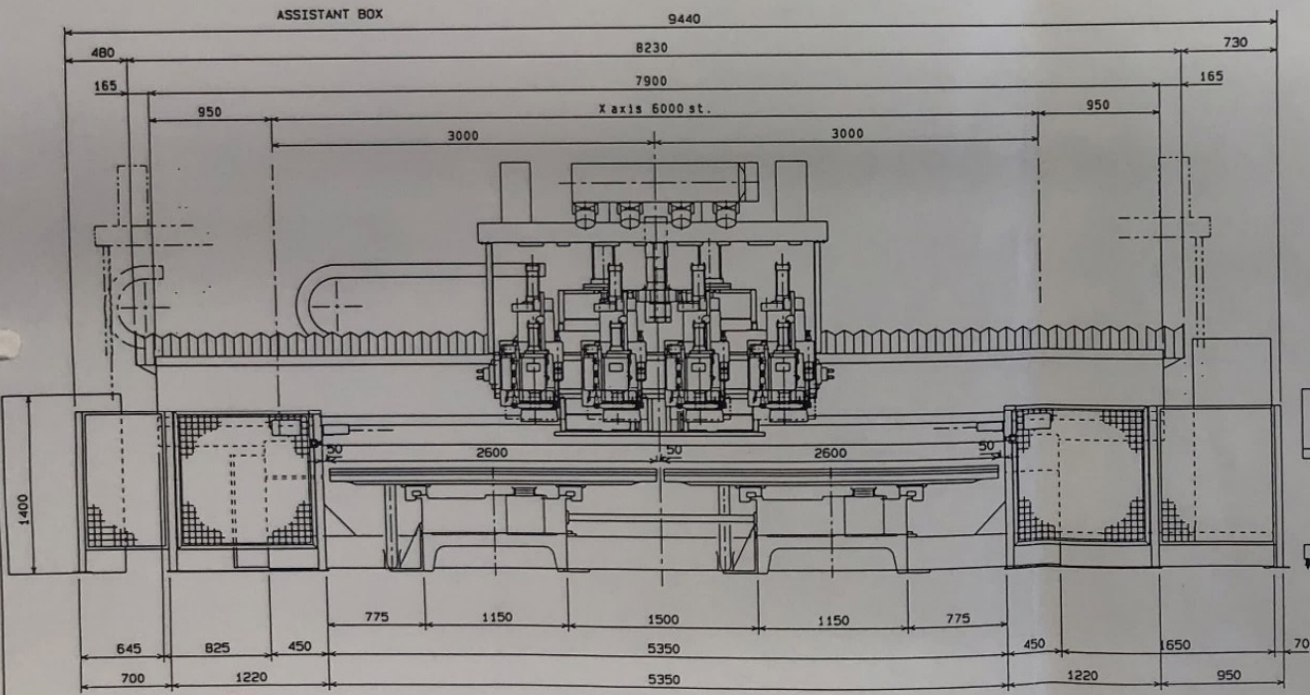

No.	1	2	3	4	5	6	7	8	9	10	11	12	13	14	15	16	17	18	19	20
Model	NC-442PMC-2616M																			
Name	NC Router Machine																			
General	General Drawing																			
Scale	1/20																			
Code	N98003-B01																			